

Using Ohm's law to analyze circuits

Ohm's law can be used to predict any of the three variables given the other two. Sometimes you want to know the current in the circuit. Sometimes you want to know voltage or resistance. Use the problem-solving steps to help set up and work through problems.

Example A light bulb with a resistance of 2 ohms is connected to a 1.5 volt battery as shown. Calculate the current that will flow.

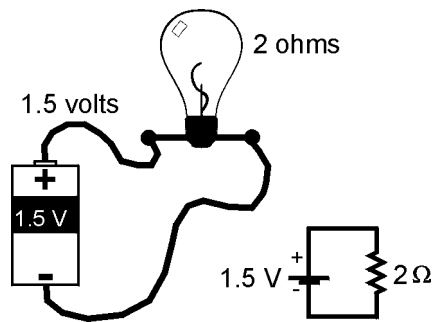

Solution:

- (1) We are asked for the current, I .
- (2) We know V and R .
- (3) Use the formula $I = V \div R$.
- (4) Plug in numbers.
 $I = 1.5 \text{ V} \div 2 \Omega = 0.75 \text{ A}$

Answer: 0.75 amps will flow in the circuit.

Example A light bulb requires 3 amps to produce light. The resistance of the bulb is 1.5 ohms. How many batteries do you need if each battery is 1.5 volts?

- (1) We are asked for the number of batteries, which means we need to know the voltage since each battery is 1.5 volts.
- (2) We know current and resistance.
- (3) Use the formula $V = IR$.
- (4) Plug in numbers.
 $V = 3 \text{ A} \times 1.5 \Omega = 4.5 \text{ V}$

Answer: Each battery can produce 1.5 volts so we need three batteries to get the required 4.5 volts.

