

Colliding Pendulum

Assembly Instructions

The Colliding Pendulum is a versatile and engaging equipment module that allows students to investigate concepts in conservation of momentum, harmonic motion and natural frequency. The following instructions show the basic steps for setting up the Colliding Pendulum.

Colliding Pendulum

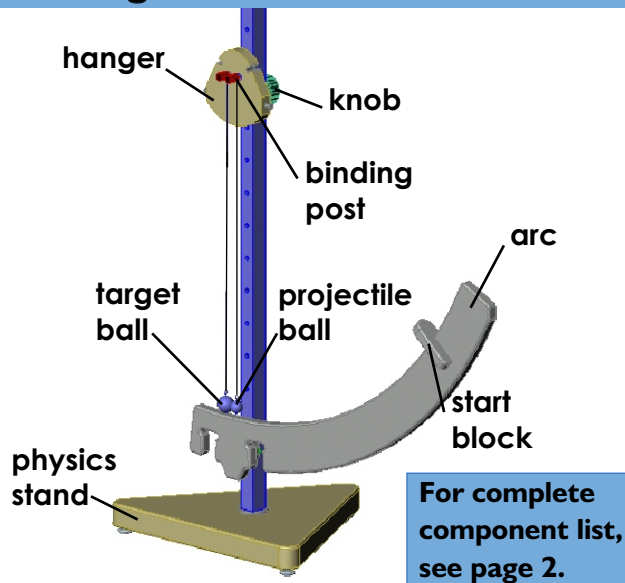

Aligning the Components

1. The Physics Stand. Stand back and look at the string. Adjust the right or left leveling pad on the Physics Stand (as necessary) until the string is lined up with the alignment mark. *Figure A*

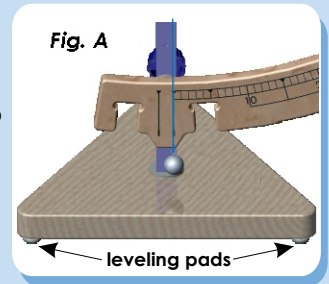

Next, adjust the third leveling pad until the string just touches the face of the arc. Your Physics Stand is now level.

2. The Hanger. Loosen the threaded knob and tilt the hanger as necessary to align the string with the zero degree line, then re-tighten the knob. *Figure B*.

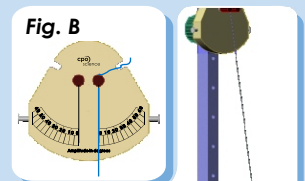

3. The Projectile Ball. (It is easier for two people to do this step together.) To set the length of the projectile pendulum, place the start block at the 10-degree position with the hole facing the pole. Fit the projectile ball into the hole. Loosen the string's binding post and pull it taut, while keeping the ball seated in the start block hole. Then re-tighten the post. One student can hold the ball while the other student pulls the string and tightens the binding post. *Figure C*.

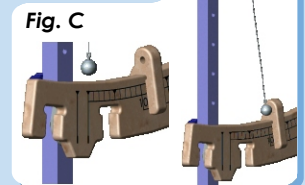

4. The Arc. (It is easier for two people to do this step together.) Place the start block at the 50-degree position. Loosen the knob on the arc and tilt the arc until you can fit the projectile ball into the hole of the start block while keeping the string taut and the start block in place. Re-tighten the knob on the arc. *Figure D*.

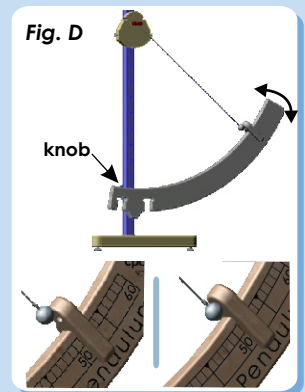

5. The Target Ball. Thread the target ball through the left binding post. Adjust it so that the centers of the target ball and projectile ball are at the same height. Tighten the binding post. *Figure E*.

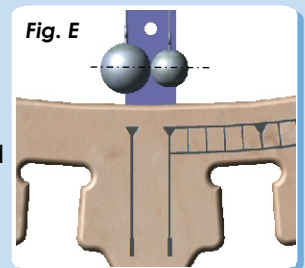

Positioning Components on Stand

1. Assemble the Physics Stand so that the holes line up with one of the edges of the triangular base. *Figure A*.

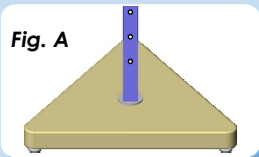

2. Attach the arc to the lowest possible hole securing it with a threaded knob. *Figure B*.

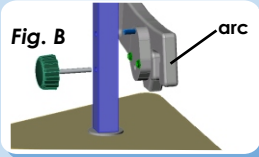

3. Leaving nine holes uncovered in between, attach the hanger to the pole above the arc, and secure it with a threaded knob. *Figure C*.

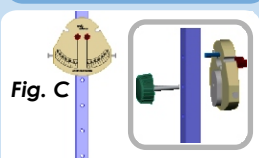

4. Loosen the right-hand binding post and insert the string from one of the balls - this will be the projectile ball. *Figure D*.

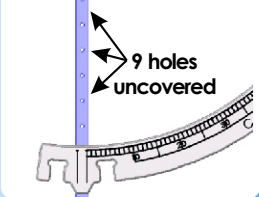

5. Gently tighten the post leaving the ball hanging slightly below the arc body. *Figure E*.

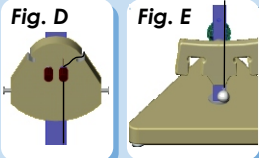

Setup information continues on page 2

Colliding Pendulum

Assembly Instructions

Setting up for Time Measurement

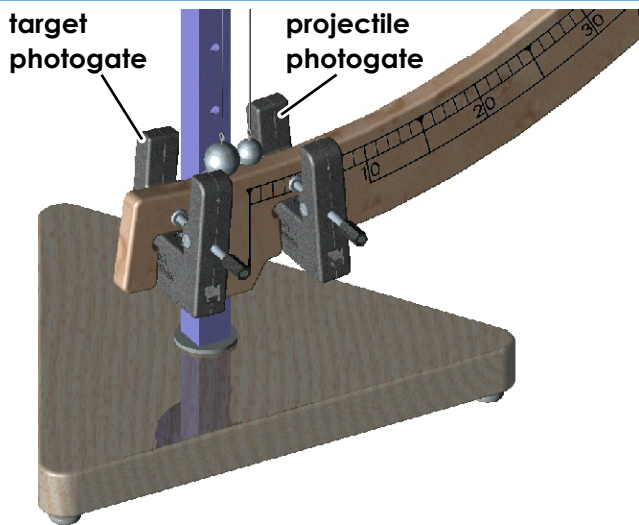

1. The Photogates. Attach the photogates to the arc as pictured above.

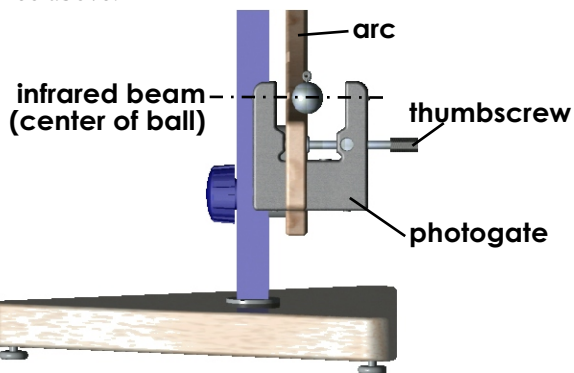

Make sure that the photogate is snug against the underside of the arc. If the Colliding Pendulum is set up as directed in the **Aligning the Components** section, the infrared beam of the photogate will be broken by the center (diameter) of ball. *This important because it allows for the calculation of speed based upon each ball's diameter.*

2. The Timer. Connect the photogates to the Timer console so that the projectile photogate is connected to the A slot on the console and the target photogate is connected to the B slot. See your timer manual for details on operating the CPO Timer.

Making a Collision

1. The Start Block. Slide the start block on to one of the notched slots on the arc.

2. To release the ball, grip it between two fingers and hold it against the pocket in the front side of the start block. The pocket ensures that the projectile ball drops from the right place to hit the center of the target ball. Release the ball by opening your fingers evenly, allowing the ball to drop straight out of the pocket.

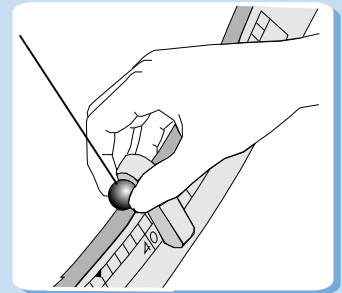

Configurations

Harmonic Motion:

Using the same basic configuration as the conservation of momentum experiments, students can study harmonic motion by changing the length of the string or the size (mass) of the pendulum and see the effects these variables have on the period of motion.

Using the pins on the sides of the hanger (as pictured at left), students can perform impressive qualitative studies of harmonic motion by simultaneously releasing pendulums of different mass or length and observing the motion side by side!

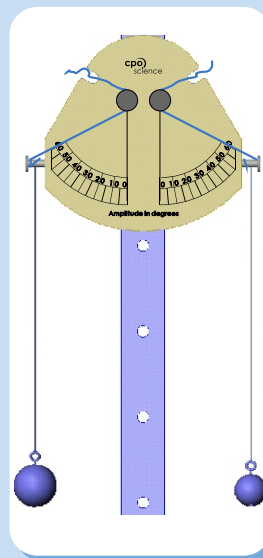

Colliding Pendulum Components

Included with Colliding Pendulum:

arc	pendulum balls:
hanger	1 - large (1-1/4")
start block	2 - medium (1")
2 - threaded knobs	1 - small (3/4")

For technical assistance, please call 866.588.6951.